

CERAMIC DISC CAPACITOR

Suntan®

CLASS I TEMPERATURE COMPENSATION

TS15

FEATURES

- Linear temperature coefficient of capacitance.
- High stability of capacitance.
- Low loss at wide range of frequency.

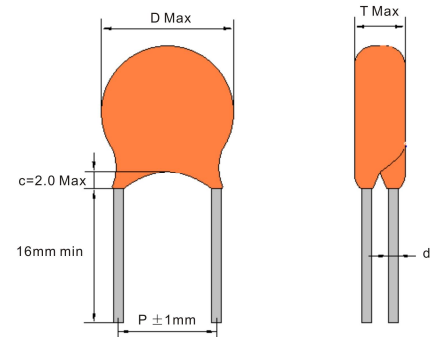
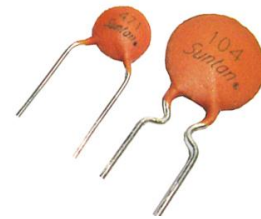

SPECIFICATIONS

OPERATING TEMPERATURE RANGE	-25°C TO +85°C
RATED WORKING VOLTAGE	DC 50V, 100V, 500V
TEST VOLTAGE	3 times of the rated voltage
CAPACITANCE	Within the tolerance at 1 MHz, 1±0.2 Vrms. 25°C
Q FACTOR	At 1 MHz. 1±0.2 Vrms. 25°C C≥30pFQ≥1,000 C<30pFQ≥400+20°C (C: Rated capacitance)
INSULATION RESISTANCE	10,000 MΩmin.

Capacitance	Rated Volt. (VDC)	Tolerance	Material	D Φmax (mm)	T max (mm)	Pitch ±1mm	d ±0.05mm
1pF~9pF	50V	±0.25pF	NPO	6	3.5	2.54 / 5.08	0.4
10pF~22pF	50V	±5%	NPO	6	3.5	2.54 / 5.08	0.4
		±10%	NPO	6	3.5	2.54 / 5.08	0.4
		±10%	NPO	5	3.5	2.54 / 5.08	0.4
23pF~120pF	50V	±5%	SL	6	3.5	2.54 / 5.08	0.4
		±10%	SL	6	3.5	2.54 / 5.08	0.4
150pF~220pF	50V	±5%	SL	6	3.5	2.54 / 5.08	0.4
		±10%	SL	6	3.5	2.54 / 5.08	0.4
330pF~820pF	50V	±10%	Y5P	6	3.5	2.54 / 5.08	0.4
1000pF	50V	±10%	Y5P	6	3.5	2.54 / 5.08	0.4
1200pF~2200pF	50V	±10%	Y5P	6	3.5	2.54 / 5.08	0.4
2700pF~3300pF	50V	±10%	Y5P	7	3.5	2.54 / 5.08	0.4
4700pF	50V	±10%	Y5P	6	3.5	2.54 / 5.08	0.4
6800pF	50V	±10%	Y5P	6	3.5	2.54 / 5.08	0.4
2200pF~8800pF	50V	±20%	Y5U	6	3.5	2.54 / 5.08	0.4
0.01uF	50V	+80-20%	Z5V/Y5V	6	3.5	2.54 / 5.08	0.4
		±20%	Y5V	7	3.5	2.54 / 5.08	0.4
		±20%	Y5V	6	3.5	2.54 / 5.08	0.4
		±10%	Y5P	6	3.5	2.54 / 5.08	0.4
0.015uF~0.022uF	50V	±10%	Y5P	6.6	3.5	2.54 / 5.08	0.4
		+80-20%	Y5V	6	3.5	2.54 / 5.08	0.4
		±20%	Y5V	6	3.5	2.54 / 5.08	0.4
		±20%	Y5U	6	3.5	2.54 / 5.08	0.4
0.033uF~0.047uF	50V	+80-20%	Y5V	6	3.5	2.54 / 5.08	0.4
		±20%	Y5V	6	3.5	2.54 / 5.08	0.4
		±20%	Y5U	6	3.5	2.54 / 5.08	0.4
0.047uF	50V	±10%	Y5P	9.5	3.5	5.08	0.5
0.068uF~0.1uF	16V	+80-20%	Y5V	6.4	3.5	2.54 / 5.08	0.4
	25V	+80-20%	Y5V	6.6	3.5	2.54 / 5.08	0.4
	50V	+80-20%	Y5V	7	3.5	2.54 / 5.08	0.4
0.068uF~0.1uF	25V	±20%	Y5V	6.6	3.5	2.54 / 5.08	0.4
	50V	±20%	Y5V	7	3.5	2.54 / 5.08	0.4
	50V	±20%	Y5V	8	4.0	2.54 / 5.08	0.5
	50V	±20%	Y5U	9	4.0	5.08	0.5
0.1uF	50V	±10%	Y5P	10	4.0	5.08	0.5
0.15uF~0.22uF	50V	+80-20%	Y5V	9.5	4.0	5.08	0.5
		±20%	Y5U	9.5	4.0	5.08	0.5

Note: Specification are subject to change without notice. For more detail and update, please visit our website.