

TS25-05

FEATURES

- Tantalum case, Hermetically Sealed, Cylindrical, Radial-lead, Heteropolarity, with screws, convenient to fix.
- Commingled by Electrolytic Tantalum Capacitor and Electrochemical Capacitor, Small size, Super Capacitance
- Stable in Electrical Performances, High Reliability, Long life-span, Maximum in the Density of Capacitance and Energy, Nominal Capacitance is higher than TS25-04 series
- Built-in as battery in Energy-converted-circuit & Power-pulsed-circuit, functioned as filtering, storage energy, time-delay circuit.

SPECIFICATIONS

Operating Temperature	-55°C to +125°C (to +125°C, with rated voltage derating)
Storage Temperature	-62°C ~ +130°C
Capacitance Tolerance	Q: (-10%~+30%), K: (±10%), M: (±20%)



Electrical Characteristics

Rated Voltage (V)	Category Voltage (V)	Surge Voltage (V)	Cap. (µF)	tgδ (%)	ESR (Ω) 1kHz	DCL (µA)		Impedance at (Ω) 100Hz	Capacitance Change at (%)			Dimensions
						25°C	85°C, 125°C		-55°C	-55°C	+85°C	DxH
10	6	11	100000	180	0.035	300	1800	1	-80	+160	35.5x12	
			150000		0.025						35.5x16	
16	9.5	17.6	60000	165	0.035	300	1800	1	-80	+160	35.5x12	
			90000		0.025						35.5x16	
25	15	27.5	36000	130	0.04	300	1800	1	-75	+160	35.5x12	
			54000		0.035						35.5x16	
35	20	38.5	24000	95	0.04	300	1800	1	-70	+160	35.5x12	
			36000		0.035						35.5x16	
50	30	55	11000	65	0.1	300	2400	1.2	-60	+120	35.5x10	
			12000	65	0.1	300					35.5x12	
			16000	70	0.04	400					35.5x12	
			18000	70	0.04	400					35.5x12	
			24000	70	0.035	400					35.5x16	
63	38	70	8000	50	0.04	400	2400	1.4	-45	+90	35.5x12	
			12000		0.035						35.5x16	
80	48	88	5600	40	0.06	500	3000	1.6	-40	+90	35.5x12	
			8200		0.04						35.5x16	
100	60	110	2400	35	0.08	500	3000	1.8	-30	+80	35.5x12	
			3800		0.05						35.5x12	
			3600		0.05						35.5x16	
			5700		0.05						35.5x16	
110	66	121	1200	35	0.08	500	3000	2	-25	+60	35.5x12	
			1800		0.075						35.5x16	
			3000		0.075						35.5x16	
			4500		0.075						35.5x16	
125	75	138	1100	30	0.08	500	3000	2.4	-25	+50	35.5x12	
			1600		0.075			2.4	-25	+50	35.5x16	
			2200		0.075			2.4	-25	+50	35.5x12	
			3300		0.05			2.4	-25	+50	35.5x16	
			3300		0.05			2.2	-20	+45	35.5x19	

TS25-05

Dimensions (unit: mm)

Φ35.5x10/12/16/19 Layout (A Type)

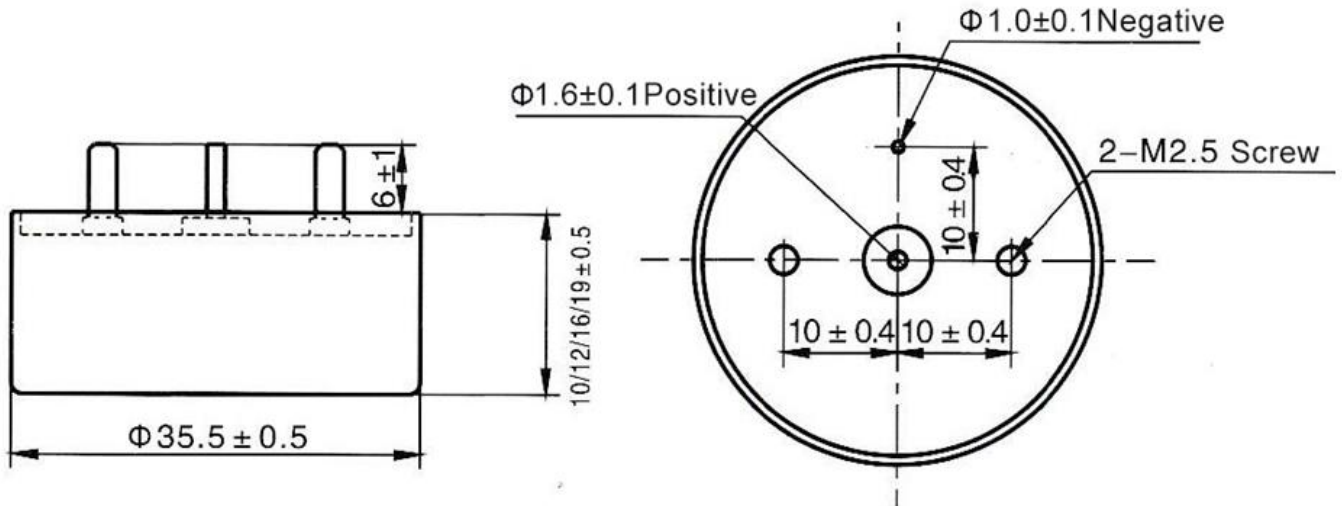

Φ35.5x10/12/16/19 Layout (B Type)

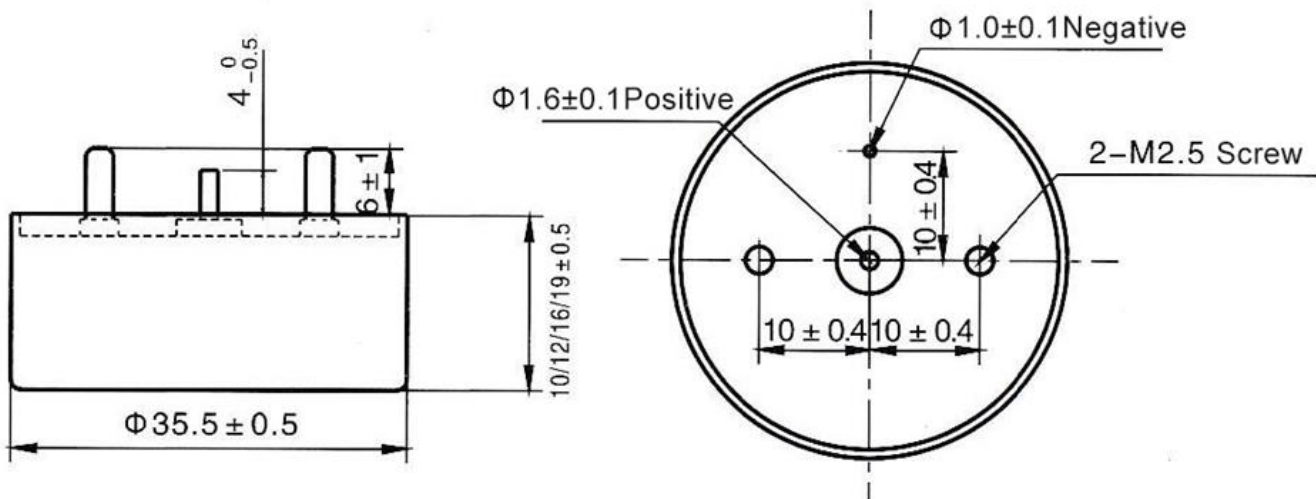

Note:

1. Please do not use multimeter through the measuring procedures (may cause irreversible damage and lead to discard).
2. Capacitance and DF measured at 100Hz, $U_+ = 2.20^{0}_{-1.0}$ V, $U_- = 1.0^{0}_{-0.5}$ V Test only applied in series equivalent circuit.
3. Voltage derating is applied at +125°C. (The DCL parameter should be read after 5 minutes when it connected to the circuit).
4. Special size and demand could consult with us.

Note: Specifications are subject to change without notice. For more details and updates, please visit our website.